



www.lvs-inc.com

LVS[®] 7000

An In-line Process Control System that Improves the Quality Inspection Process



In-Line Print Quality Inspection

- Press
- Rewind
- Sheet Fed
- Carton
- And Much More...



LVS 7000 In-line Vision Inspection

TRUE 100% INSPECTION

Inspect and map any number of fields at any size repeat, in any orientation across the form or print web!

- Identify Blemishes
- DELTA E Color Process Control
- Check for Duplicates
- Sequential/Random Validation



- ISO Read and Grade 1D and 2D barcodes including QR Code, ECC-200 Data Matrix, Composite Code and many more
- OCR and OCV
- Holograms/Reflective/Security Marks
- Roll Mapping

DELTA E – Color Process Control

Color detection allows the LVS® 7000 to detect color variances on labels by comparing the master color to the current image color in the field of view.

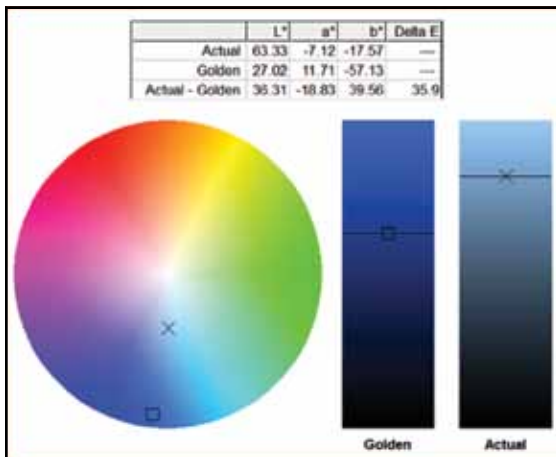

“Color detection allows customers to monitor their color process and ensure they have a color match from beginning to end,” said Scott Lydell,

North America Sales Manager for LVS®.

The color detection feature, also referred to as the Delta E module, continuously calculates the average $L^*a^*b^*$ values of all the pixels within a sector according to CIE 2000 specifications. The Delta E functionality works best with solid colors.

Blemish - Master-to-Label Module

The system compares every label to a Master image chosen at the beginning of the run or stored from a previous

job. The Automatic Setup feature quickly identifies foreground (text), background (solid color blocks), and die cuts allowing you to focus in on the areas that matter most. This module also includes a robust set of tools that allow you to identify and create print sectors that can be treated uniquely by adjusting sensitivities for those regions.

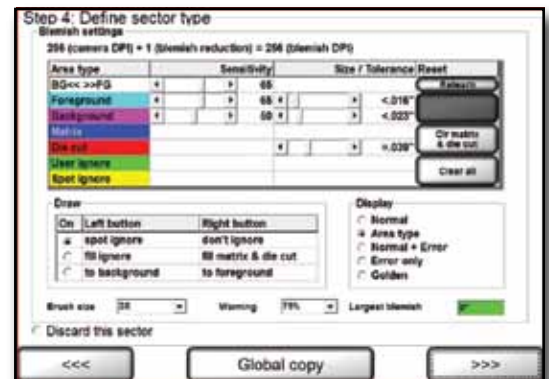

Foreground Background



The Master-to-Label module will allow you to accurately identify and track any type of potential print error you may encounter including print to die registration, die cut errors, broken letters, skews, smears, spots, voids, wrinkles, hickies and other print quality defects.

Complete Data Validation Package

Includes OCV, OCR, File Matching, Numbering Validation and Duplicate Checking

The LVS® 7000 combines OCR, OCV and barcode reading/grading modules to read and/or verify data against a data file or some programmable set of factors.

Capabilities include:

- Cross reference unique independent sectors (barcode to eye-readable text)
- Check Random or Sequential Data (ascending or descending)
- Check for duplicates either against a white list or from scratch
- Perform OCV on fonts as small as 4 points

ISO Verification Module

The LVS® 7000 ISO Verification Module verifies any combination of linear, matrix and stacked codes to ISO print quality standards. The bar codes can be in any orientation, with any number and mix of codes on a label. The various parameters of the ISO Print Quality guidelines are made up of measurements dealing with both reflectance and structural rules for a given symbol. Unlike bar code validation, the ISO Verification module actually reads and analyzes the symbol to published specifications (ISO 15415 & 15416) and then gives that symbol an overall ANSI/ISO grade based on those specifications.

LVS® Roll Inspection Mapping (RIMS) Module

LVS® RIMS was designed to complete your workflow process. Linked to the LVS® 7000 system, LVS® RIMS will map and record each error detected on the press. The electronic mapping file can be called up remotely with the QC Manager to be pre-cleaned for errors and special directions entered for the finishing operator. Using a simple and easy to use tracking module, LVS® RIMS will automatically stop the rewind (rewind must be capable).



LVS® HMI Command Center

The LVS® Human Machine Interface (HMI) Command Center is beneficial for customers needing to view and interact with multiple vision systems in remote

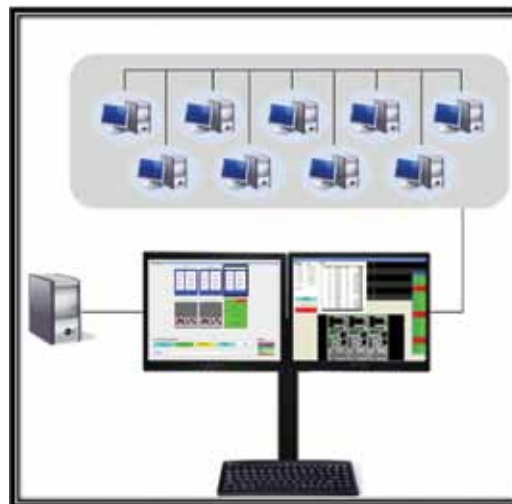

locations from a single monitor. The system uses a dual-monitor console to view and fully interact with a maximum of nine LVS® 7000/7500 systems or non-LVS® systems.



System Specifications

Rate of travel, web width and minimum bar width or smallest point sizes will impact camera resolution recommendation

Camera Hardware

- Types: Line scan and Area Scan options
- Resolution: 2K, 4K, 8K and 12K

Lighting Options

- Red, white and custom diffused options for foil and holograms

PC Hardware

- Multi-core Processor. Windows® XP and 7 operating system

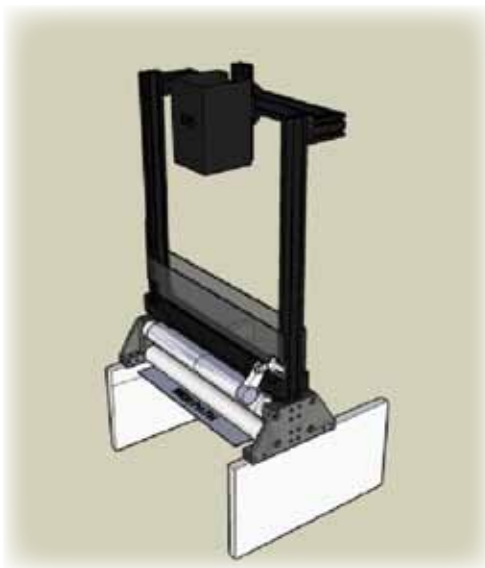

Cabinetry/Mounting Options

- Choose either Hoffman Cabinet or Ergotron Arms. Actual system footprint will vary based on camera/PC and lighting requirements
- Mounts on a press, slitter/rewinder, folder gluer, conveyor, and most other inspection platforms

I/O

- 8 digital outputs for programmable alarm and trigger requirements

Electrical

- 110VAC @ 60 Hz or 240VAC @ 50Hz

ISO Grading Specifications

- ISO 15416, ISO 15415, GS1 and other application standards

Current Symbolologies

Aztec Code	GS1 Databar-14
Codabar	Interleaved 2 of 5 (ITF)
Code 128	Micro QR Code
Code 39	MicroPDF417
Code 93	Pharmacode - Laetus
Data Matrix	PDF-417
DataBar expanded	QR Code
EAN-8 & EAN-13	UPC-A & UPC-E
GS1 128 with CCA	and all applicable
CCB	GS1 composite
CCC	components
GS1 Databar Limited & Stacked	

Software Specifications

- Graphics-oriented user interface under Windows® XP and 7 operating system
- Multiple password protection security levels
- 21 CFR Part 11 compliant ready with on board record keeping and job tracking
- Automatic Setup feature for click and go changeovers
- Reporting, logs and summary reports for Quality Assurance managers stored as CSV files for portability
- Information is date and time stamped

LVS® RIMS

- Digitally store ALL errors and accept/reject errors. Control links to finishing systems – I/O stop signal
- Includes light tower, HMI, encoder, ergotron arm, processor, software, label printer & barcode scanner

Quality Control Manager

- Remotely review errors, accept and reject errors prior to finishing. Customer to provide own PC running Windows® XP or 7 operating system

